



TwinTech Ultimate Combi Caster - Total Lock with Cable Sweeper

Move cables and cords aside with ease when transporting mobile equipment. Helps prevent entanglements and accidental unhooking of machines and devices.

Applications

- Hospital Beds
- Day Care and Long-term Care Beds
- Mobile Electronic Equipment
- Anesthesia Machines
- Imaging Equipment
- Laser Surgery Equipment
- Other Complex or Mobile Equipment



Conforms to ISO 22881: 2004

Strong

Pressure die-cast aluminum body provides high strength without the material cost or greater weight of other caster types.

Maneuverable

45-degree cam movement, ball bearing swivel head, and sealed precision wheel bearings for ease of movement.

Durable

Nylon 6 molded wheels are rugged and lightweight.

Quiet

Hard-wearing polyurethane tires provide a smooth, quiet ride.

Attractive

Sleek, aesthetic design with a high-quality, RAL 9003 matte white finish.



Toll-Free: 1-888-883-3596
www.RevvoCaster.com

TwinTech Ultimate Cable Sweeper Caster

Combi Central-locking Caster Sets

- Specially-designed set of fully-enclosed, positive mechanical system that locks all casters simultaneously.
- Maintenance-free braking with no adjustments required.
- Swivel lock and brakes operate securely and independently, improving performance.
- Dynamic braking allows for operation of brake while casters are in motion without damage to the mechanism.
- Enhanced, reliable design for improved performance with fewer components.

Dimensions (mm)

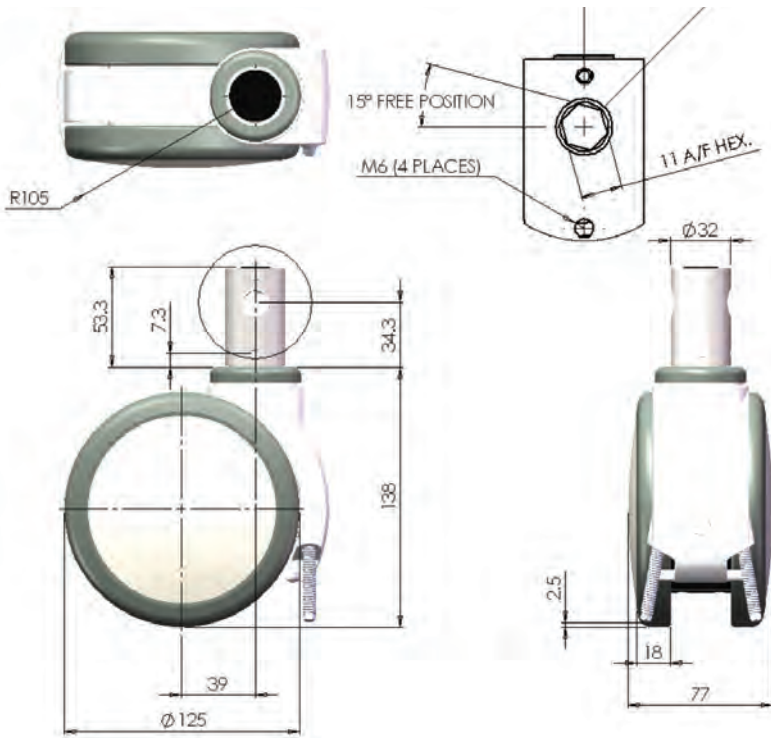

Technical Data

Load capacity	135 kg (298 lb.)
Wheel diameter	125 mm
Tread width	18 mm
Caster width	77 mm
Swivel radius	105 mm
Offset	39 mm
Durometer	90° Shore A
Body color	Matte White RAL 9003 (other colors optionally available)
Tread color	Gray



The Revvo Caster Company, Inc.
Turn your product designs around

2420 North America Drive, West Seneca, NY 14224
Phone: 716-675-9609 • Fax: 716-677-2363 • Toll-Free: 1-888-883-3596
Email: info@revvocaster.com • www.RevvoCaster.com

