



GB SERIES

Gang Box Caster Kits

Convenient Gang Box Caster Kits from Revvo provide everything needed to add casters to a new mobile toolbox or replace casters on an existing tool, work, job, or gang box.

With load capacities from 1,800 to 3,000 lbs., these heavy-duty, light-weight casters are specially designed to handle heavy loads and withstand hard impacts. The polypropylene wheels with roller bearings are resistant to most chemicals, oils, acids, and greases.

- Forged caster assembly for extra strength
- Bolt patterns match most popular brand name gang boxes
- Grease zerk fitting for easy caster lubrication of swivel wheel
- Durable, weather-resistant zinc finish

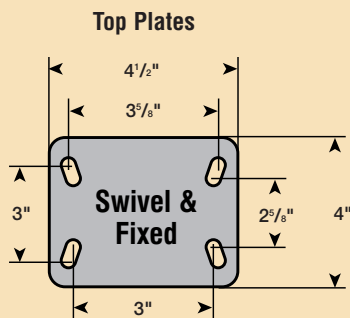

Gang Box Kit top plates are 1/4" thick and have fixing holes to suit 3/8" diameter bolts.



Complete kit includes two swivel and two rigid casters with polypropylene wheels in 4", 5" or 6" diameters, plus 16 attaching bolts and lock washers.

Options

- Swivel caster brakes
- Self-tapping attaching bolts
- Kit with all swivel casters
- Alternate wheels for special applications

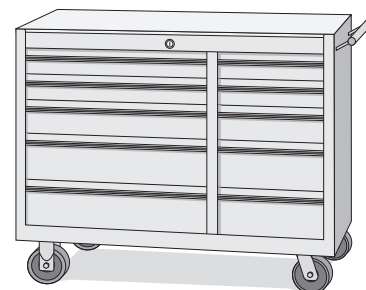

GB SERIES

Wheel Dia.	Overall Height	Tread Width	Total Load Capacity (lbs.)	Bearing Type	Wheel Construction	Kit Part #
4"	5-9/16"	2"	1800	Roller	Polypropylene	4GB PL1G
5"	6-1/2"	2"	2600	Roller	Polypropylene	5GB PL1G
6"	7-1/2"	2"	3000	Roller	Polypropylene	6GB PL1G

To order self-tapping attaching bolts, add suffix - K or suffix - DLT to Part #.
To order brakes on swivel casters, add suffix - B to Part #.

Attaching Hardware Sizes:

Standard:	3/8" - 16 x 3/4"	long
- K:	5/16" - 18 x 3/4"	long, self-tapping
- DLT:	3/8" - 16 x 1"	long, self-tapping



The Revvo Caster Company, Inc.
"Moving in the right direction"

The Revvo Caster Company, Inc.
 2420 North America Drive • West Seneca, NY 14224
 Phone: 716-675-9609 • Fax: 716-677-2363
 Toll-Free: 1-888-883-3596
 E-Mail: info@revvocaster.com • www.RevvoCaster.com