

JA Series Swivel Jacking Casters

Flexello JA Series jacking casters are designed to facilitate movement and quick, accurate adjustment of working platforms, machines, and other applications. Ideal for medium and heavy-duty loads, they feature an electrostatic-sprayed black matte finish.

The JA Series casters are available in sizes ranging from 6" to 10" wheel diameters with load capacities from 880 to 5,500 lbs. (400 to 2,500 kg). The 6" and 8" models have a screw jacking system with a 3" lift independent of the swiveling action. The 10" model has a 6" lift and features a 2-way directional lock with travel at 90° to the vertical fixing plate.

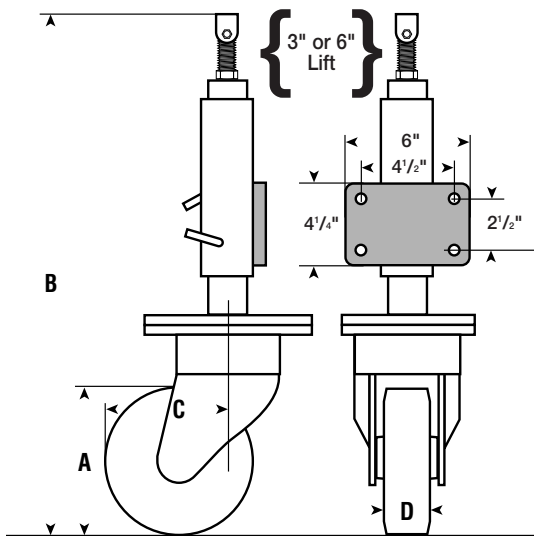
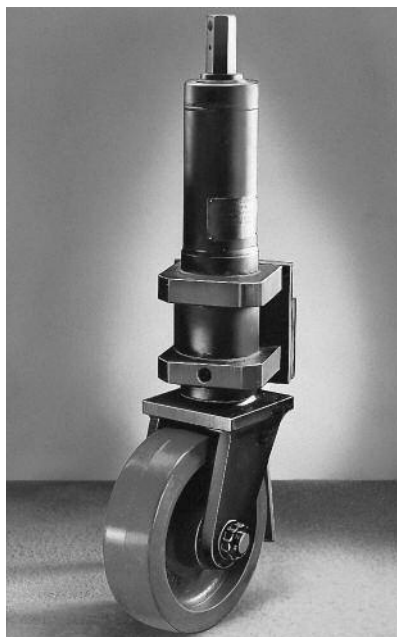

Plate dimensions shown for 6" and 8" diameter models. The bolt-hole pattern for 10" diameter models measures 4" by 4". Consult factory for additional details on 10" models.



JA Series with 10" Wheel Diameter and 6" Lift



JA Series with 3" Lift

A = Wheel Diameter B = Overall Height C = Swivel Radius D = Tread Width

JA SERIES								
A	B	C	D	Load Capacity	Bearing	Wheel	Swivel Part #	
6"	21-7/8"	5-3/8"	1-3/4"	880	Roller	Rubber on Cast Iron	JA-6RTB	
6"	21-7/8"	5-3/8"	1-3/4"	1600	Roller	Polyurethane on Cast Iron	JA-6SUB	
6"	21-7/8"	5-3/8"	1-3/4"	2240	Roller	Cast Iron	JA-6CIB	
8"	23-7/8"	6-3/8"	2"	1285	Roller	Rubber on Cast Iron	JA-8RTB	
8"	23-7/8"	6-3/8"	2"	2300	Roller	Polyurethane on Cast Iron	JA-8SUB	
8"	23-7/8"	6-3/8"	2"	2400	Roller	Cast Iron	JA-8CIB	
10"	29-3/8"	7-3/4"	3"	5500	Ball Journal	Polyurethane on Cast Iron	JA-210SUTML	

Operation is by means of a 30mm A.F. ratchet lever or conventional spanner or hexagonal socket, which must be removed immediately after the jacking operation.



The Revvo Caster Company, Inc.

2420 North America Drive, West Seneca, NY 14224
 P.O. Box 236, Fort Erie, ON L2A 5M9
 TOLL-FREE: 1-888-883-3596 • Phone: 716-675-9609 • Fax: 716-677-2363
 E-Mail: info@revvocaster.com • www.RevvoCaster.com